

REVISIONS				
ZONE	REV.	DESCRIPTION	DATE	APPROVED
	A	APPROVED SUBMITTAL	11/08/2016	11/08/2016
	B	ALL HARDWARE ADDED TO MODEL.	09/07/2017	09/07/2017

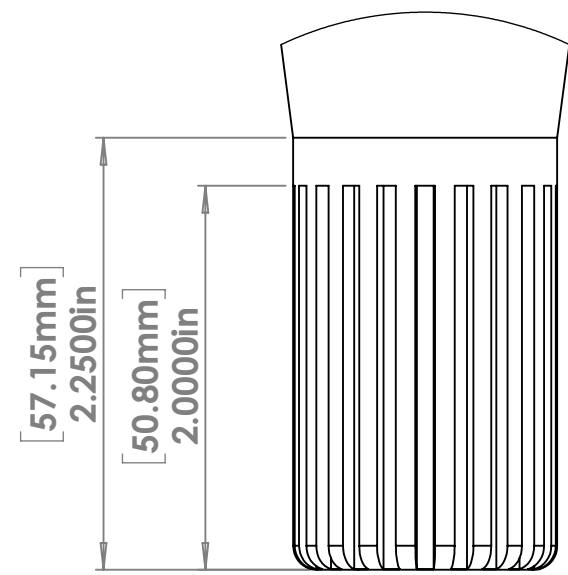

DETAIL A  
SCALE 1:1

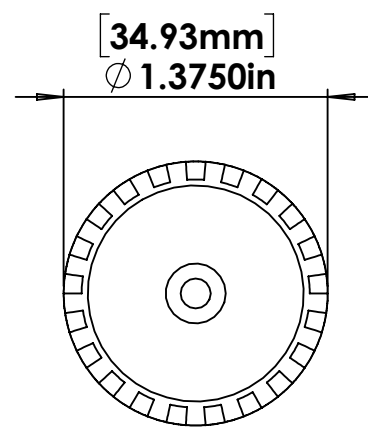
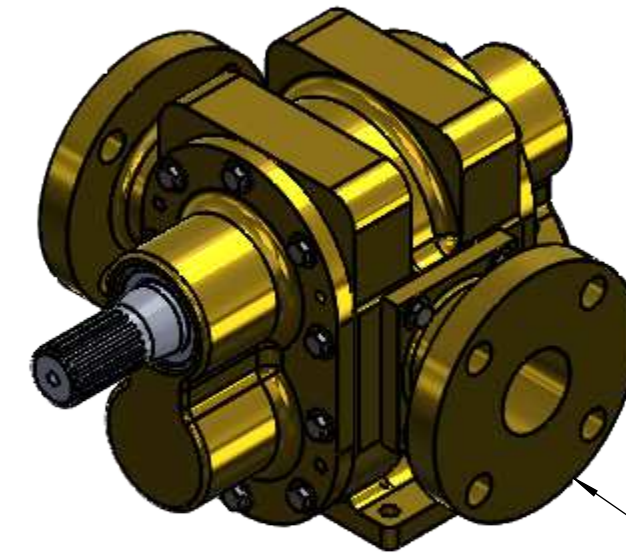
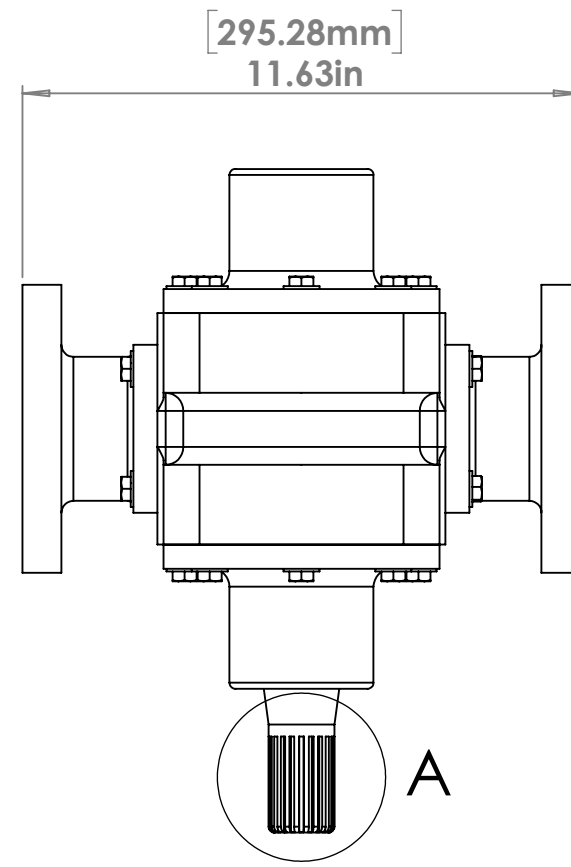

DETAIL B  
SCALE 1:1

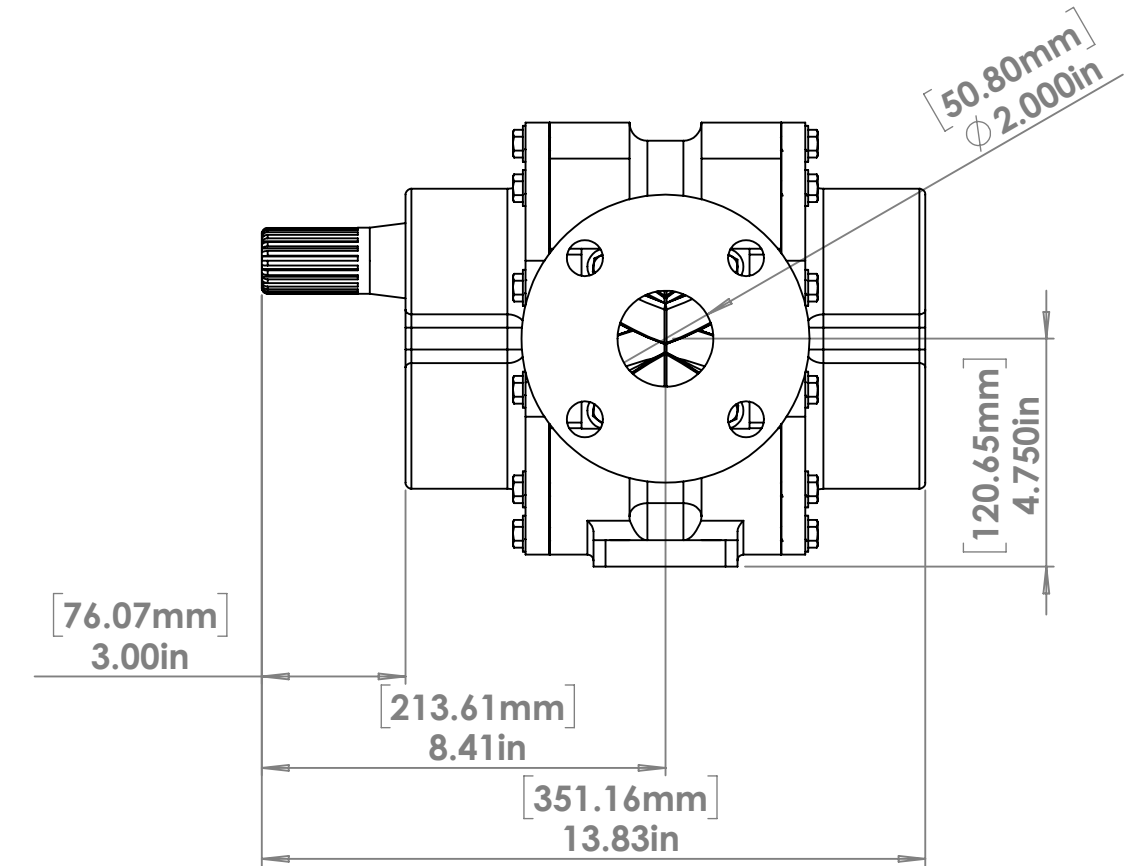
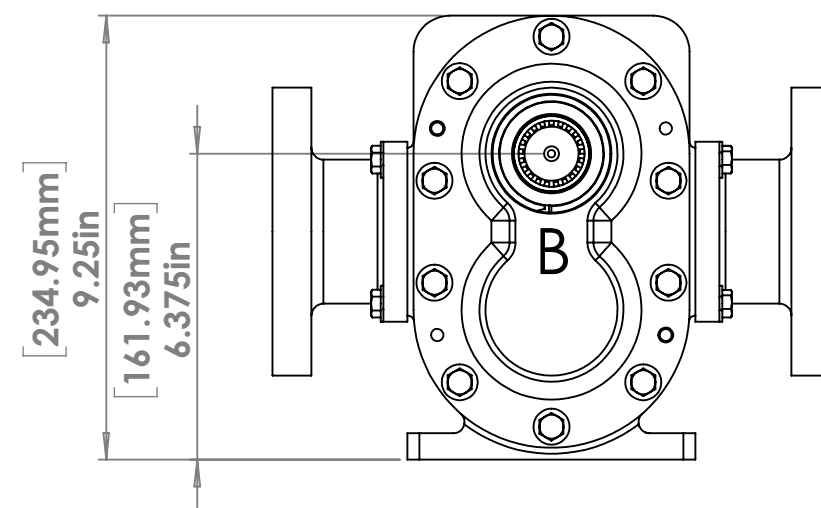

NOTE: The spline is a 21 tooth, 16/32 pitch, 30 degree, flat root, side fit, involute spline.

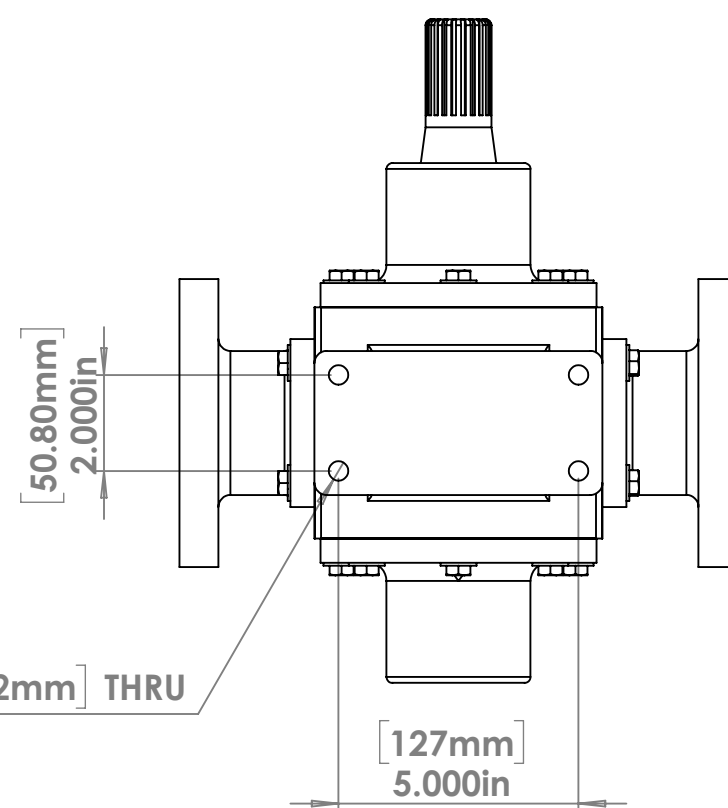

PROPRIETARY AND CONFIDENTIAL  
THE INFORMATION CONTAINED IN THIS DRAWING IS THE SOLE PROPERTY OF FIRE LION GLOBAL LLC. ANY REPRODUCTION IN PART OR AS A WHOLE WITHOUT THE WRITTEN PERMISSION OF FIRE LION GLOBAL LLC IS PROHIBITED.

UNLESS OTHERWISE SPECIFIED:		NAME	DATE
DIMENSIONS ARE IN INCHES (mm)		DRAWN	SK 09/07/17
TOLERANCES:		CHECKED	TR 09/07/17
FRACTIONAL ±1/2		ENG APPR.	
ANGULAR: MACH ±1 BEND ±2		MFG APPR.	
TWO PLACE DECIMAL ±0.25		Q.A.	
THREE PLACE DECIMAL ±0.125		COMMENTS:	
FOUR PLACE DECIMAL ±0.0625		FP2-150 PUMP ASSEMBLY WITH 150# FLANGE CONNECTORS AND SPLINE DRIVE SHAFT	
INTERPRET GEOMETRIC TOLERANCING PER:	FINISH	APPLICATION	DO NOT SCALE DRAWING



TITLE: FP2-150 - Flange Spline ASSY		
SIZE	DWG. NO.	REV
C	FP2-150-0.1.1.0	B
SCALE: 1:4	WEIGHT:	SHEET 1 OF 1