

REVISIONS				
ZONE	REV.	DESCRIPTION	DATE	APPROVED
	A	APPROVED SUBMITTAL	05/11/2016	05/11/2016
	B	ALL HARDWARE ADDED TO MODEL. BOM AND EXPLODED VIEW ADDED ON 2ND PAGE.	09/05/2017	09/05/2017
2-C4	C	PART NUMBER OF ITEM NO. 17 IN BOM ON PAGE 2 CHANGED TO 154N90.	12/20/2017	12/20/2017

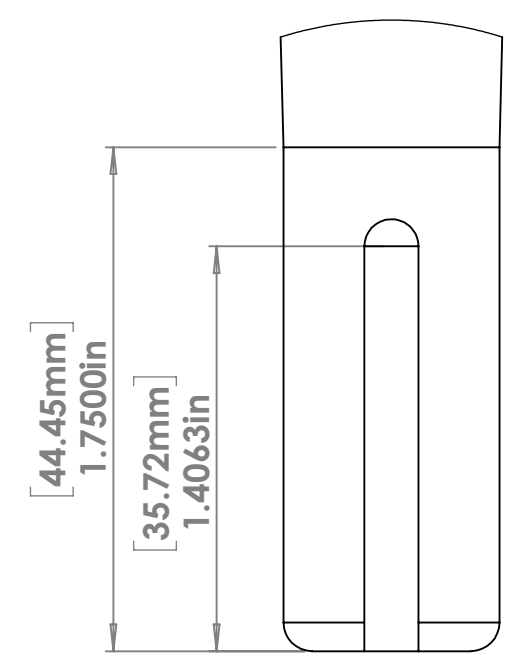

DETAIL A  
SCALE 3:2

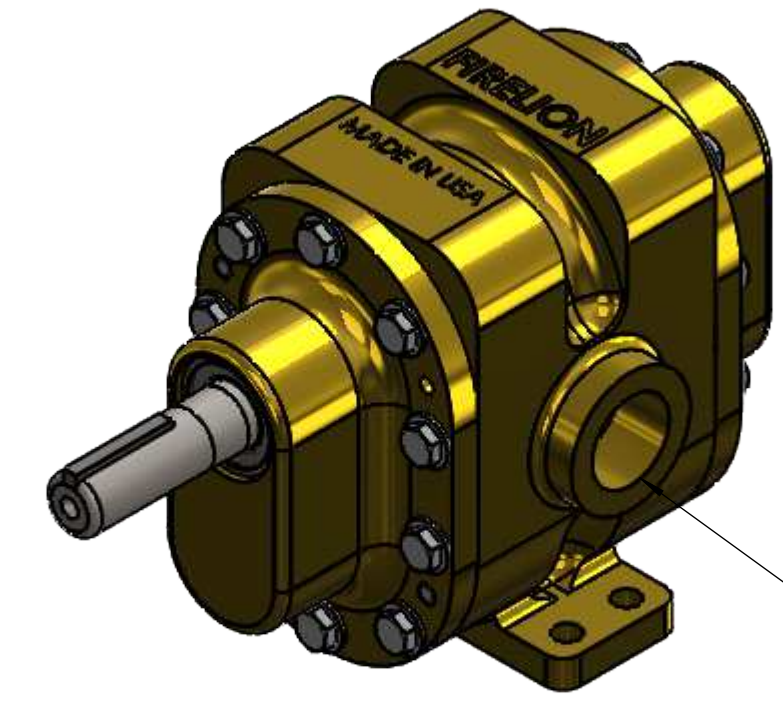
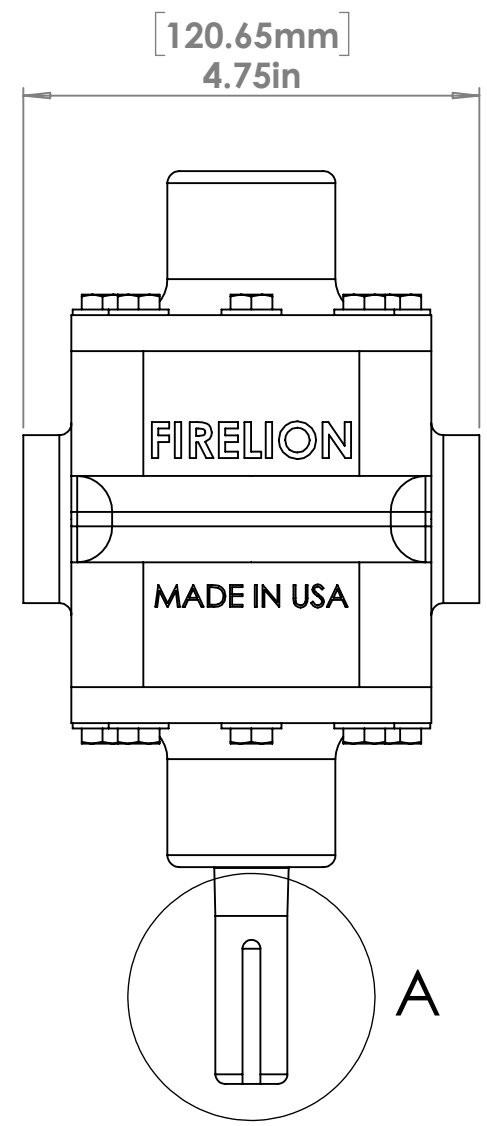

1 INCH FEMALE  
NPT THREADED  
CONNECTION

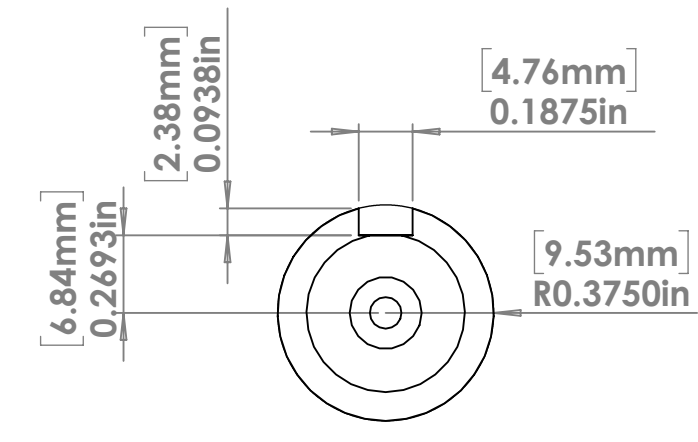

DETAIL B  
SCALE 3:2

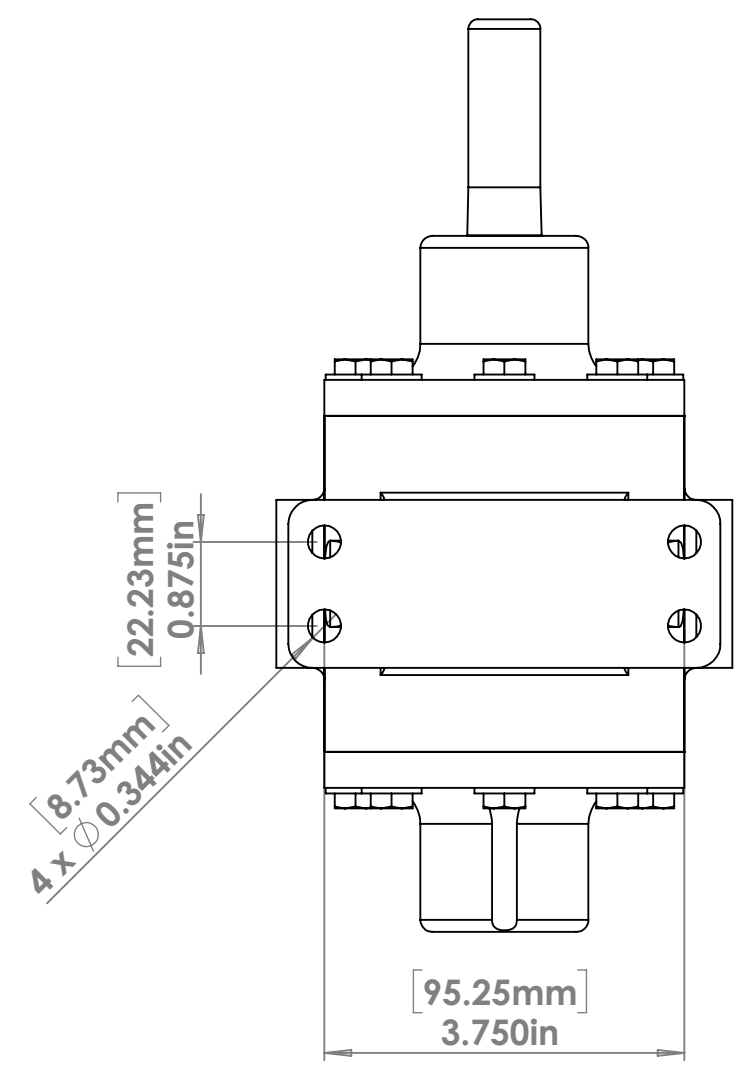
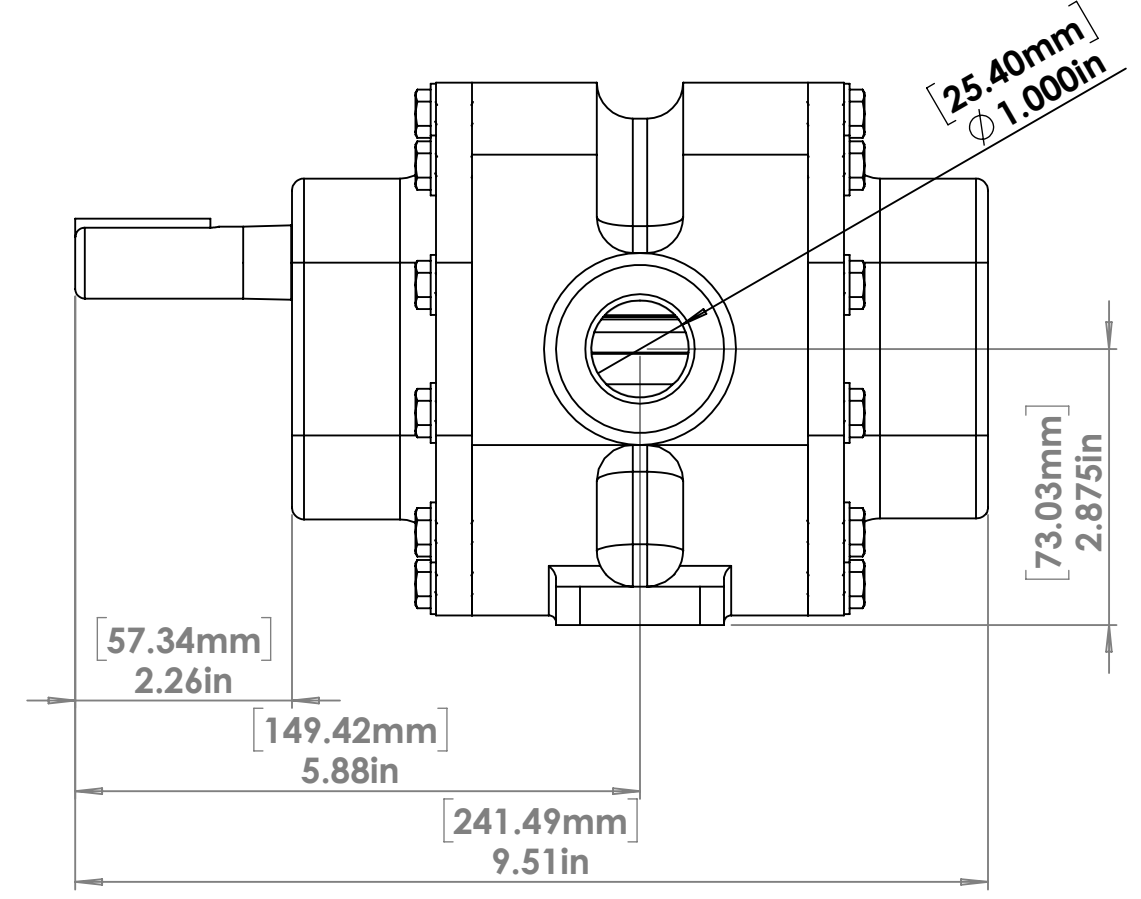
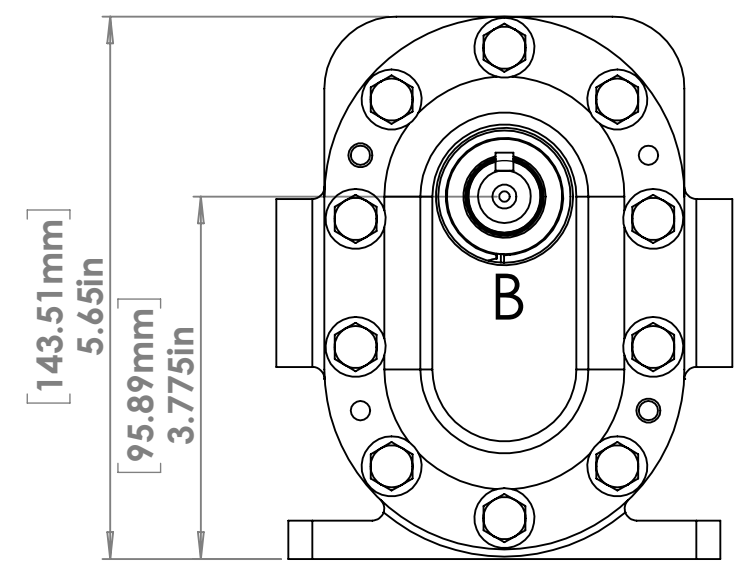

PROPRIETARY AND CONFIDENTIAL  
THE INFORMATION CONTAINED IN THIS DRAWING IS THE SOLE PROPERTY OF FIRE LION GLOBAL LLC. ANY REPRODUCTION IN PART OR AS A WHOLE WITHOUT THE WRITTEN PERMISSION OF FIRE LION GLOBAL LLC IS PROHIBITED.

UNLESS OTHERWISE SPECIFIED: DIMENSIONS ARE IN INCHES [mm] TOLERANCES: FRACTIONAL ±1/2 ANGULAR: MACH ±1 BEND ±2 TWO PLACE DECIMAL ±0.25 THREE PLACE DECIMAL ±0.125 FOUR PLACE DECIMAL ±0.0625		NAME	DATE
DRAWN	SK	12/20/17	
CHECKED	TR	12/20/17	
ENG APPR.			
MFG APPR.			
INTERPRET GEOMETRIC TOLERANCING PER:	Q.A.		
MATERIAL	COMMENTS:	FP1-15 PUMP ASSEMBLY WITH 1 INCH FEMALE NPT CONNECTIONS AND KEY DRIVE SHAFT	
FINISH			
NEXT ASSY	USED ON		
APPLICATION	DO NOT SCALE DRAWING		



TITLE:  
FP1-15 - Pump Assembly  
SIZE DWG. NO. REV  
C FP1-15-0.0.0.0 C  
SCALE: 1:2 WEIGHT: SHEET 1 OF 2

ITEM NO.	DESCRIPTION	PART NUMBER	QTY.
1	FP1_15_BODY_(MACHINE)	FP1-15-2.1	1
2	FP1_FRONT_ENDCOVER_(MACHINE)	FP1-2.2	1
3	FP1_BACK_ENDCOVER_(MACHINE)	FP1-2.3	1
4	FP1_15_IDLE_SHAFT_(GRIND)	FP1-15-1.1	1
5	FP1_15_DRIVE_SHAFT_(GRIND)	FP1-15-2.1	1
6	FP1_15_IDLE_ROTOR	FP1-15-4.1	1
7	FP1_15_DRIVE_ROTOR	FP1-15-4.2	1
8	FP1_SEAL_SPIRAL_SNAP_RING	DNH-35-S02	1
9	FP1_SEAL	501302098	1
10	FP1_SEAL_O_RING	123V75	1
11	FP1_FLANGE_BUSHING	H370FM-2528-30	4
12	FP1_DRIVE_COUPLING_KEY	98510A117	1
13	FP1_15_SHAFT_ROTOR_KEY	98530A410	2
14	FP1_GUIDE_PIN	25R75PDPS	4
15	FP1_WASHER	25NWSAS	20
16	FP1_HEX_BOLT	25C75HCSS	20
17	FP1_BODY_O_RING	Ⓒ 154N90	2
18	FP1_DRAIN_PLUG	50785K167	1

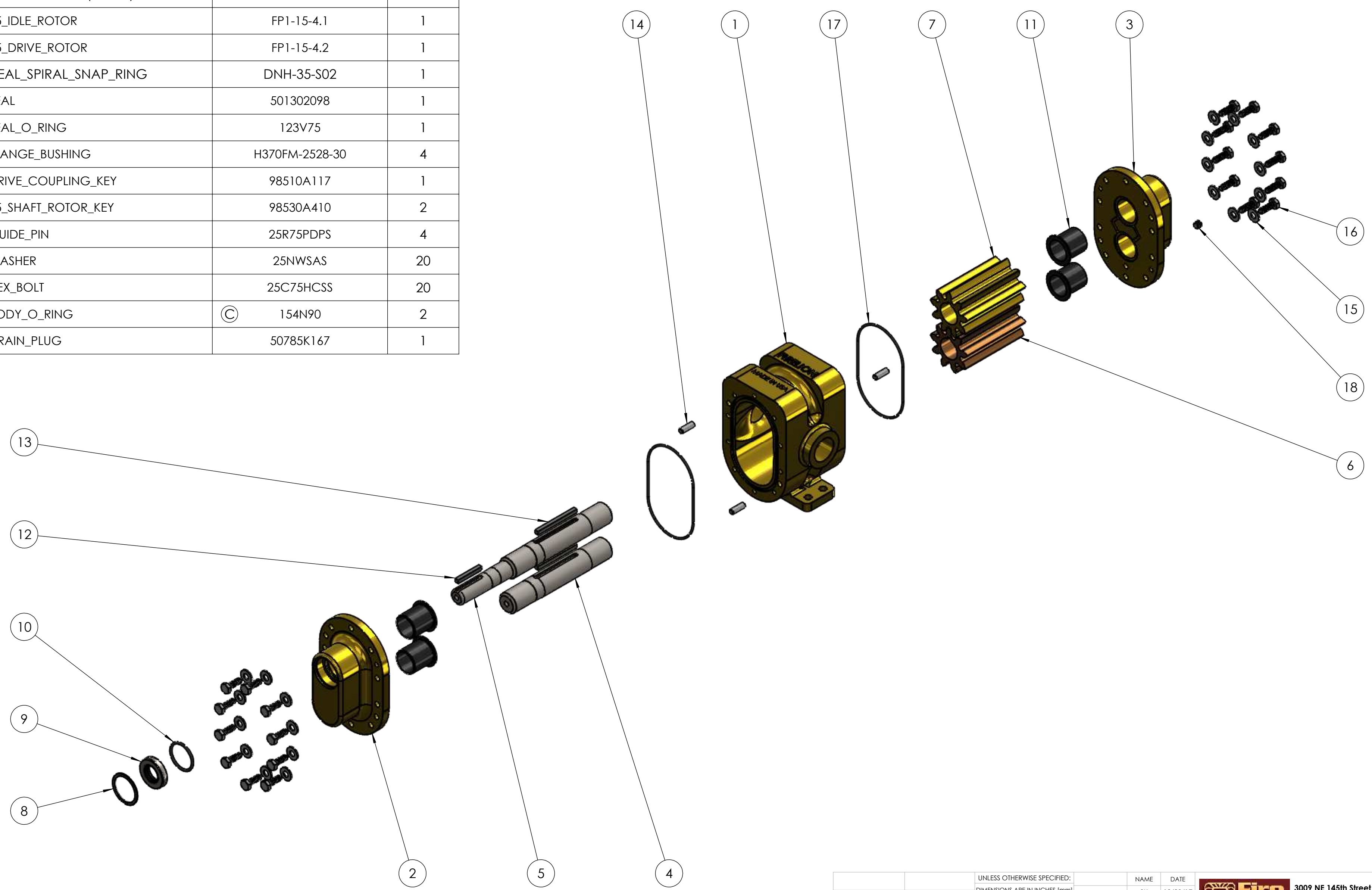

**PROPRIETARY AND CONFIDENTIAL**  
 THE INFORMATION CONTAINED IN THIS DRAWING IS THE SOLE PROPERTY OF FIRE LION GLOBAL LLC. ANY REPRODUCTION IN PART OR AS A WHOLE WITHOUT THE WRITTEN PERMISSION OF FIRE LION GLOBAL LLC IS PROHIBITED.

UNLESS OTHERWISE SPECIFIED:		NAME	DATE
DIMENSIONS ARE IN INCHES [mm]		DRAWN	SK 12/20/17
TOLERANCES:		CHECKED	TR 12/20/17
FRACTIONAL: ±1/2		ENG APPR.	
ANGULAR: MACH ±1 BEND ±2		MFG APPR.	
TWO PLACE DECIMAL ±0.25		Q.A.	
THREE PLACE DECIMAL ±0.125		COMMENTS:	
FOUR PLACE DECIMAL ±0.0625		FP1-15 EXPLODED VIEW	
INTERPRET GEOMETRIC TOLERANCING PER:		PUMP ASSEMBLY WITH 1	
MATERIAL		INCH FEMALE NPT	
FINISH		CONNECTIONS AND KEY	
DO NOT SCALE DRAWING		DRIVE SHAFT	



TITLE: FP1-15 - Exploded View		
SIZE <b>C</b>	DWG. NO. FP1-15-0.0.0.0	REV <b>C</b>
SCALE: 1:3	WEIGHT:	SHEET 2 OF 2