

REVISIONS				
ZONE	REV.	DESCRIPTION	DATE	APPROVED
	A	APPROVED SUBMITTAL	11/08/2016	11/08/2016
	B	ALL HARDWARE ADDED TO MODEL.	09/01/2017	09/01/2017

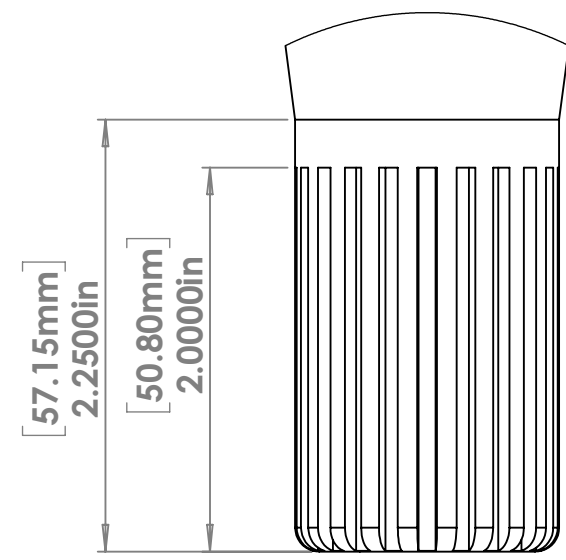

DETAIL A
SCALE 1:1

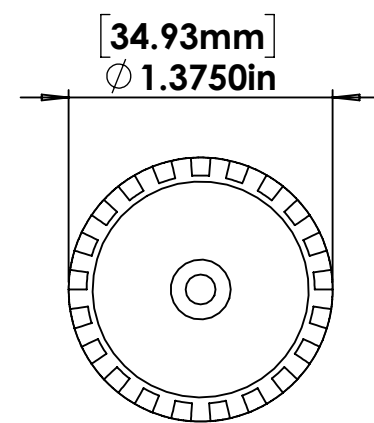
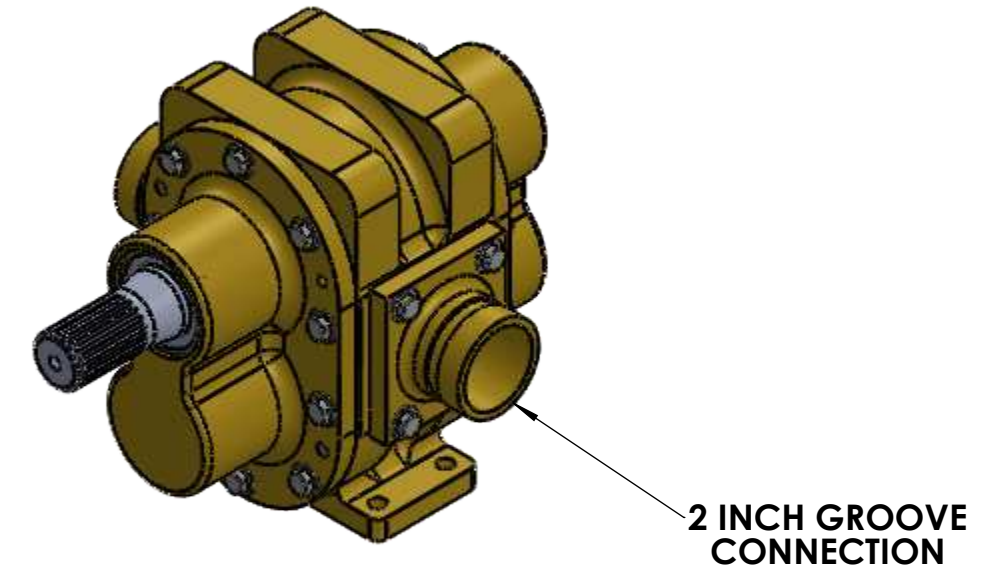
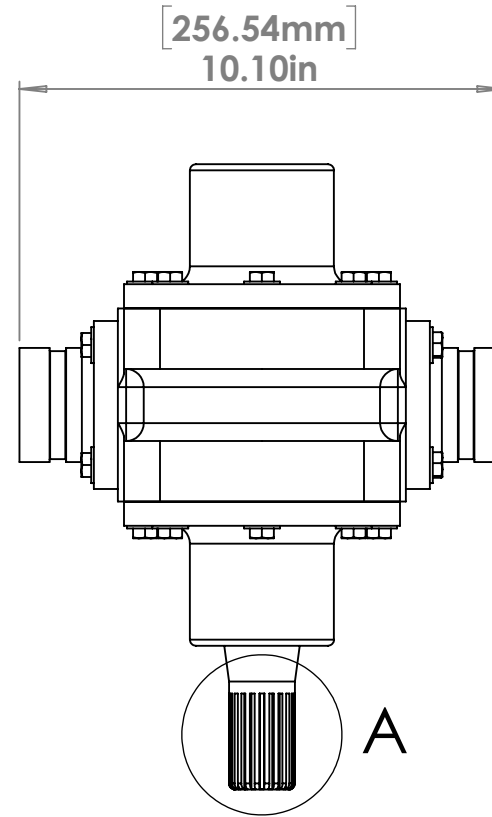

DETAIL B
SCALE 1:1

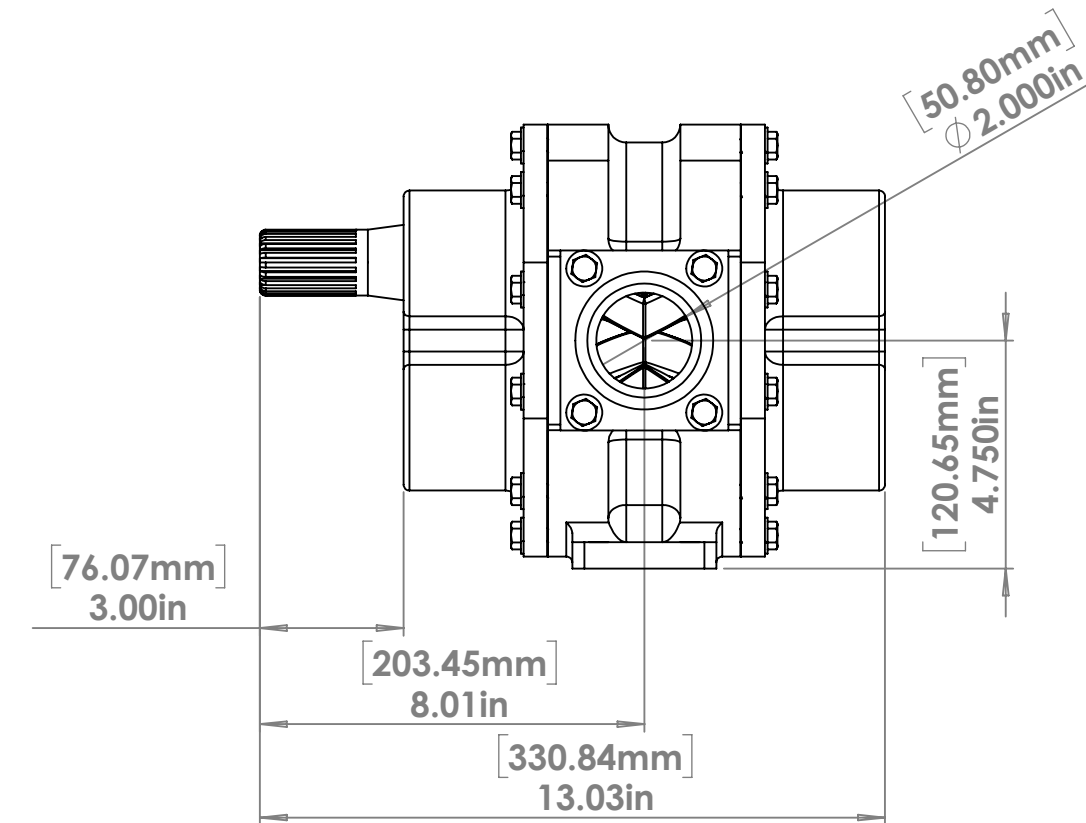
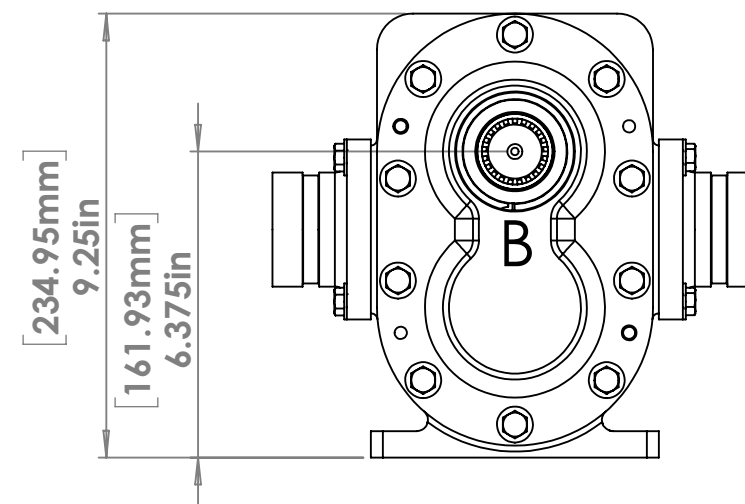

NOTE: The spline is a 21 tooth, 16/32 pitch, 30 degree, flat root, side fit, involute spline.

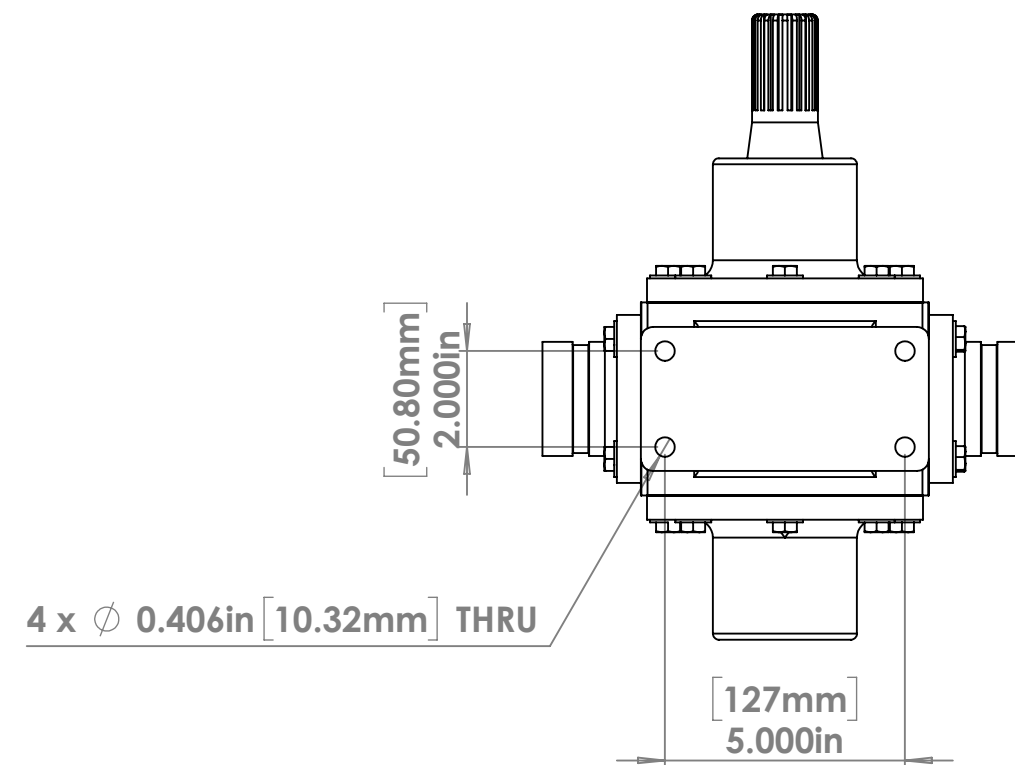

PROPRIETARY AND CONFIDENTIAL
THE INFORMATION CONTAINED IN THIS DRAWING IS THE SOLE PROPERTY OF FIRE LION GLOBAL LLC. ANY REPRODUCTION IN PART OR AS A WHOLE WITHOUT THE WRITTEN PERMISSION OF FIRE LION GLOBAL LLC IS PROHIBITED.

UNLESS OTHERWISE SPECIFIED: DIMENSIONS ARE IN INCHES [mm] TOLERANCES: FRACTIONAL ±1/2 ANGULAR: MACH ±1 BEND ±2 TWO PLACE DECIMAL ±0.25 THREE PLACE DECIMAL ±0.125 FOUR PLACE DECIMAL ±0.0625		DRAWN	SK	09/01/17
INTERPRET GEOMETRIC TOLERANCING PER:		CHECKED	TR	09/01/17
MATERIAL		ENG APPR.		
FINISH		MFG APPR.		
APPLICATION	USED ON	Q.A.		
DO NOT SCALE DRAWING		COMMENTS:	FP2-100 PUMP ASSEMBLY WITH GROOVE CONNECTORS AND SPLINE DRIVE SHAFT	



TITLE: FP2-100 - Groove Spline ASSY
 SIZE DWG. NO. REV
C FP2-100-0.2.1.0 **B**
 SCALE: 1:4 WEIGHT: SHEET 1 OF 1