

REVISIONS				
ZONE	REV.	DESCRIPTION	DATE	APPROVED
	A	APPROVED SUBMITTAL	10/26/2016	10/26/2016

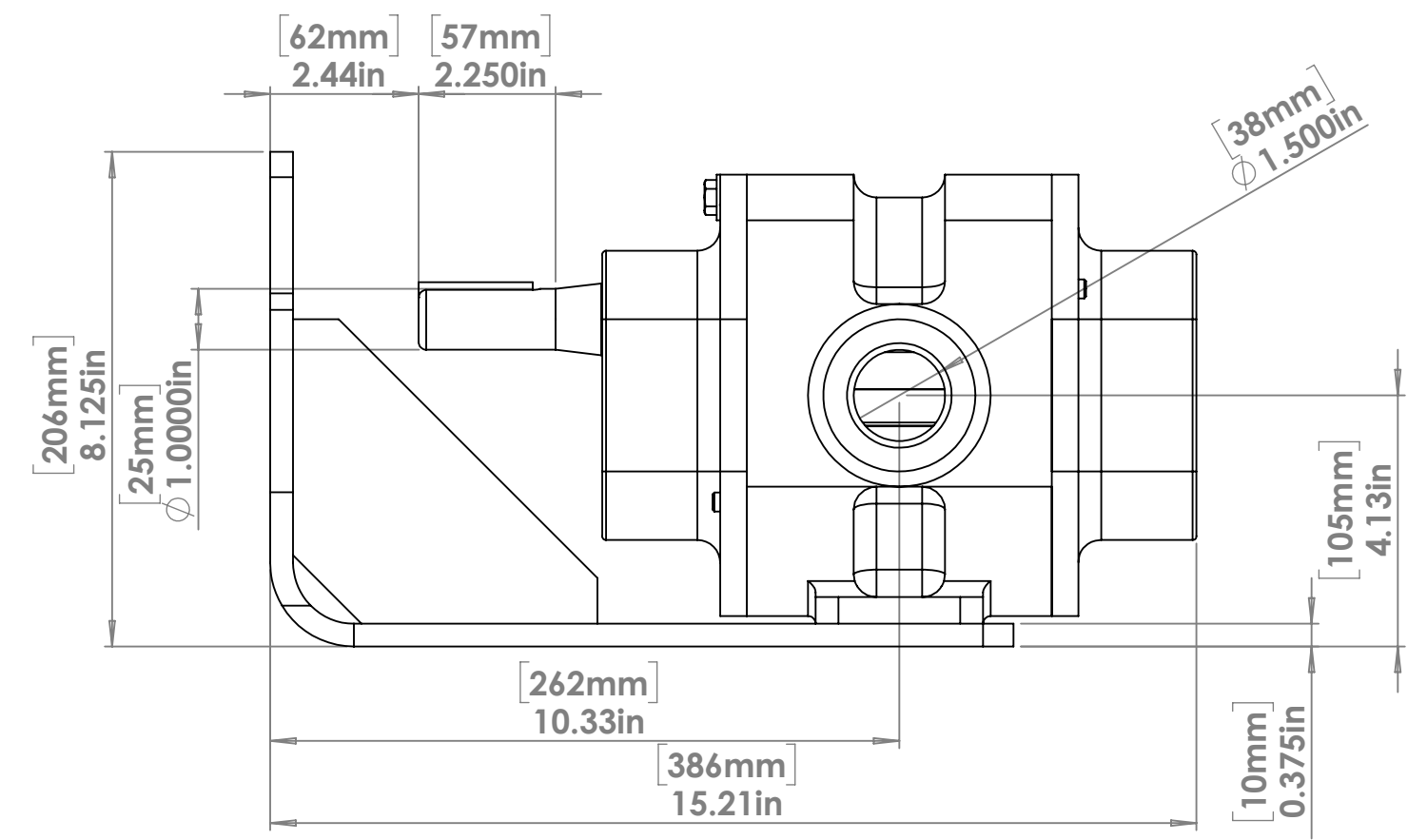
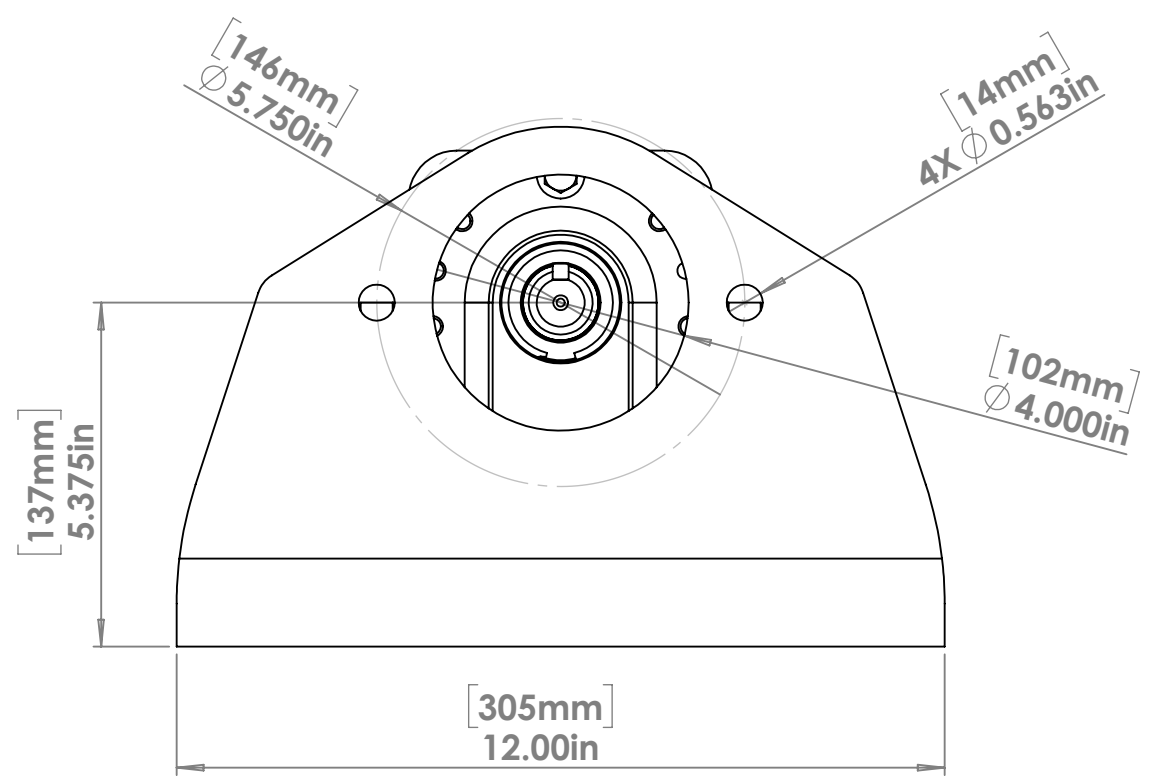
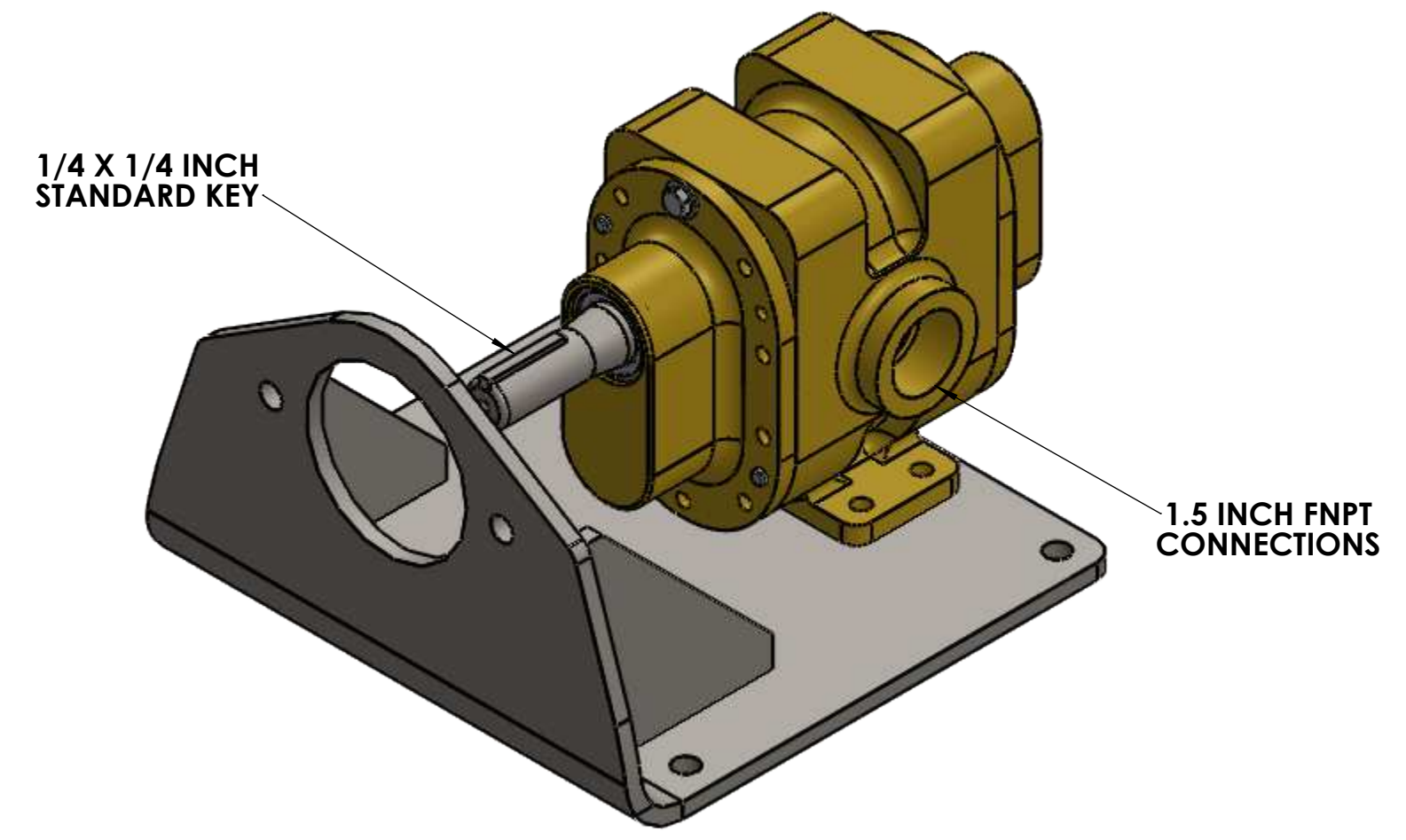
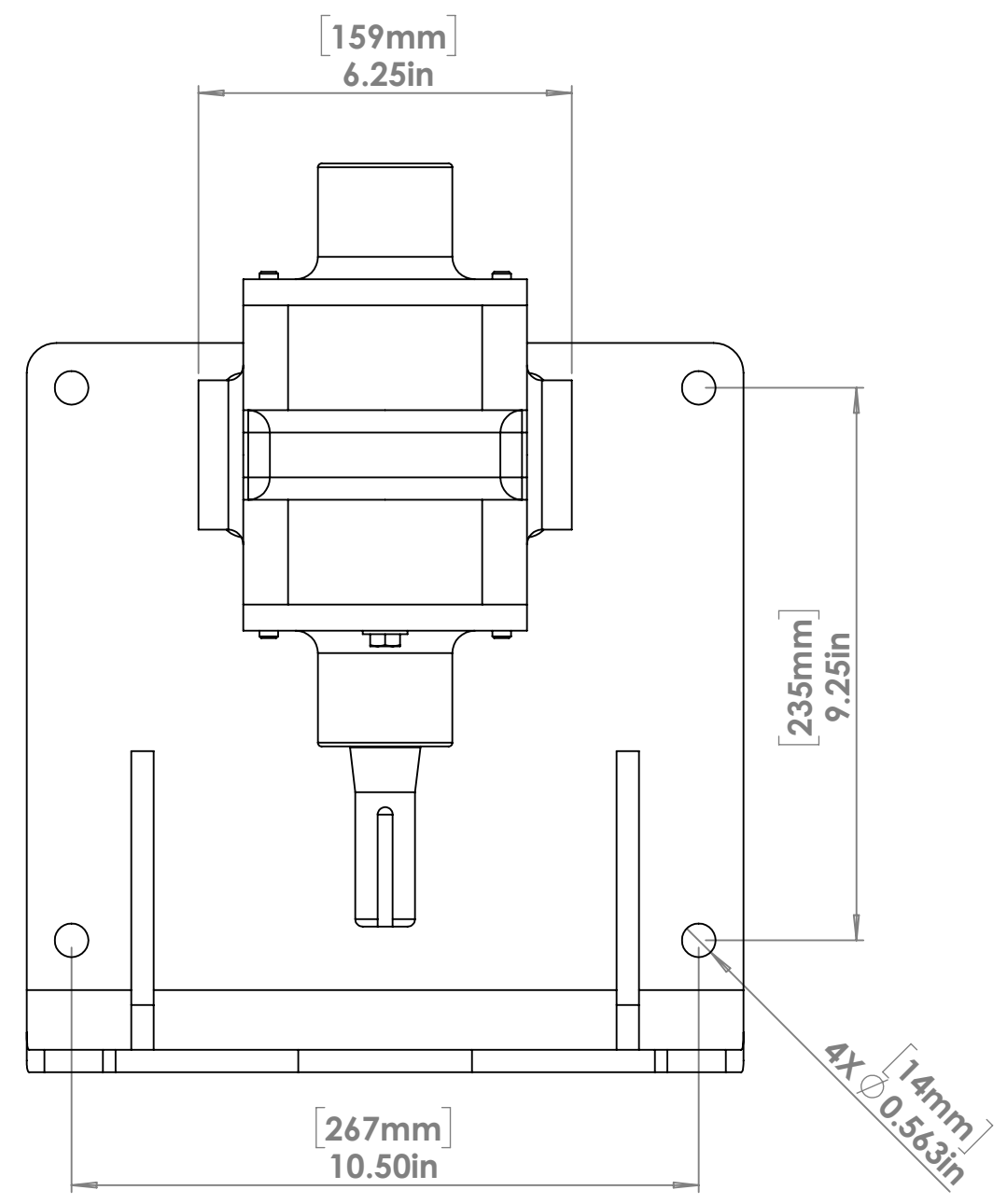

NOTES

1. HYDRAULIC DRIVE BRACKET IS DESIGNED FOR USE WITH THE 2 BOLT 'SAE B' SIZED HYDRAULIC MOTORS.
2. OTHER OPTIONS EXIST - PLEASE CONTACT FIRE LION.

PROPRIETARY AND CONFIDENTIAL
 THE INFORMATION CONTAINED IN THIS DRAWING IS THE SOLE PROPERTY OF FIRE LION GLOBAL LLC. ANY REPRODUCTION IN PART OR AS A WHOLE WITHOUT THE WRITTEN PERMISSION OF FIRE LION GLOBAL LLC IS PROHIBITED.

UNLESS OTHERWISE SPECIFIED:		NAME	DATE
DIMENSIONS ARE IN INCHES [mm]		DRAWN	SK 10/26/16
TOLERANCES:		CHECKED	TR 10/26/16
FRACTIONAL: 1/4		ENG APPR.	
ANGULAR: MACH ±1		MFG APPR.	
BEND ±1		Q.A.	
TWO PLACE DECIMAL ±0.125		COMMENTS:	
THREE PLACE DECIMAL ±0.010		FP1.5-75 - PUMP ASSEMBLY -	
FOUR PLACE DECIMAL ±0.005		FNPT CONNECTORS -	
INTERPRET GEOMETRIC TOLERANCING PER:	FINISH	KEY SHAFT - HYDRAULIC	
MATERIAL	APPLICATION	2-BOLT SAE B	
DO NOT SCALE DRAWING		DRIVE BRACKET	



TITLE:		
FP1.5-75 - 2 BOLT BRKT ASSY		
SIZE	DWG. NO.	REV
C	FP1.5-75-0.0.0.4	A
SCALE: 1:3	WEIGHT:	SHEET 1 OF 1